



Sailor

Sailor

INSTRUKTIONSBOG FOR
SAILOR COMPACT HF SSB
POWER SUPPLY N2165

INSTRUCTION BOOK FOR
SAILOR COMPACT HF SSB
POWER SUPPLY N2165



A/S S. P. RADIO · AALBORG · DENMARK

CONTENTS

1. INTRODUCTION
 - 1.1. GENERAL DESCRIPTION
 - 1.2. TECHNICAL DATA
 - 1.3. PRINCIPLE OF OPERATION AND BLOCK DIAGRAM

2. INSTALLATION
 - 2.1. MOUNTING POSSIBILITIES
 - 2.2. DIMENSIONS AND DRILLING PLAN
 - 2.3. ELECTRICAL CONNECTION AND ASSEMBLING

3. SERVICE
 - 3.1. MAINTENANCE
 - 3.2. ALIGNMENT INSTRUCTIONS
 - 3.3. PROPOSAL FOR NECESSARY TEST EQUIPMENT
 - 3.4. TROUBLE SHOOTING
 - 3.5. PERFORMANCE CHECK
 - 3.6. ADJUSTMENT PROCEDURE
 - 3.7. NECESSARY ADJUSTMENT AFTER REPAIR

- 4.1. MECHANICAL DISASSEMBLING AND MODULE LOCATION

5. CIRCUIT DESCRIPTION AND SCHEMATIC DIAGRAMS
 - 5.1. CONNECTION BOARD (MODULE 1)
 - 5.2. POWER SUPPLY (MODULE 9)
 - 5.3. INTERCONNECTION CABLE DIAGRAM

6. PARTS LIST

1.1. GENERAL DESCRIPTION

The power supply is constructed to supply RM2150 and RM2151, at the same time.

The power supply can be supplied from both AC and DC supply, as a no-break power supply.

1.2. TECHNICAL DATA

Input supply: 99 - 130V AC or 198 - 264V AC 50 Hz.
20 - 32V DC

Power consumption:

AC	AC	DC	
110V	220V	26.4V	
amps	amps	amps	
0.26	0.13	1.1	RM2150
0.26	0.13	1.1	RM2151
0.52	0.26	2.2	RM2150 and RM2151

Output voltage: 8.9V \pm .6V Max. current 1.7A
19V \pm .6V Max. current 1.0A
19V \pm .6V Max. current 0.5A

Operating temperature: -15°C to +55°C.

1.3. PRINCIPLE OF OPERATION AND BLOCK DIAGRAM

POWER SUPPLY (MODULE 9)

The power supply is designed to supply the RM2150 and RM2151.

The N2165 can be supplied from 220V AC as well as 24V DC supply.

The power supply (module 9) is supplied with 28V AC from the main transformer, or with 24V DC from the battery. The input from the main transformer is rectified and then combined with the 24V DC.

From the rectifier, the voltage is fed to the input filter, which filters the noise from the switch mode power supply. After the input filter the on/off relay is located, after which the switch control and push-pull switch transistors are located. The switch control has two external regulation loops, one for current and one for voltage regulation.

The power supply has three output voltages $\pm 19V$ and $9.5V$.

N2165
4-0-27460 - 4-0-27461

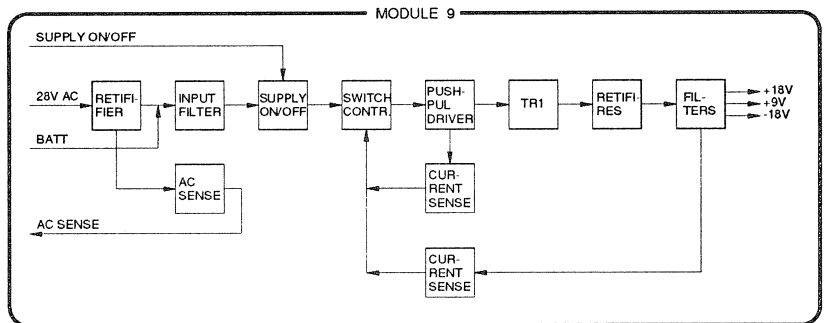
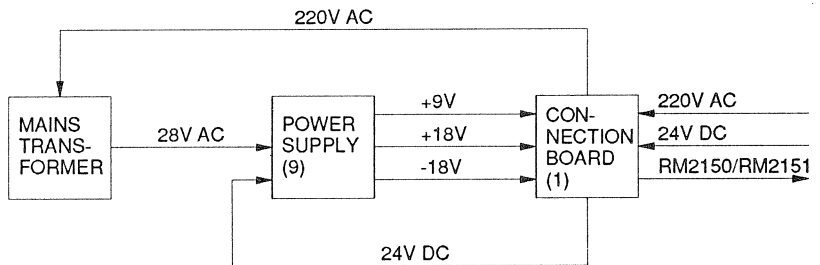

2. INSTALLATION

2.1 MOUNTING POSSIBILITIES

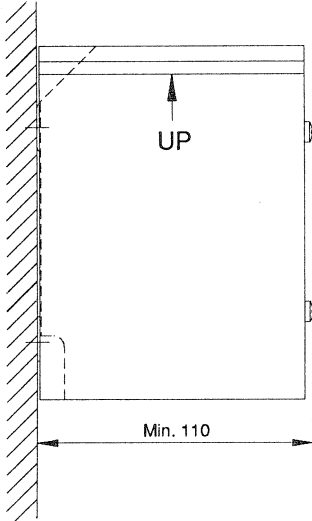

SIDE VIEW

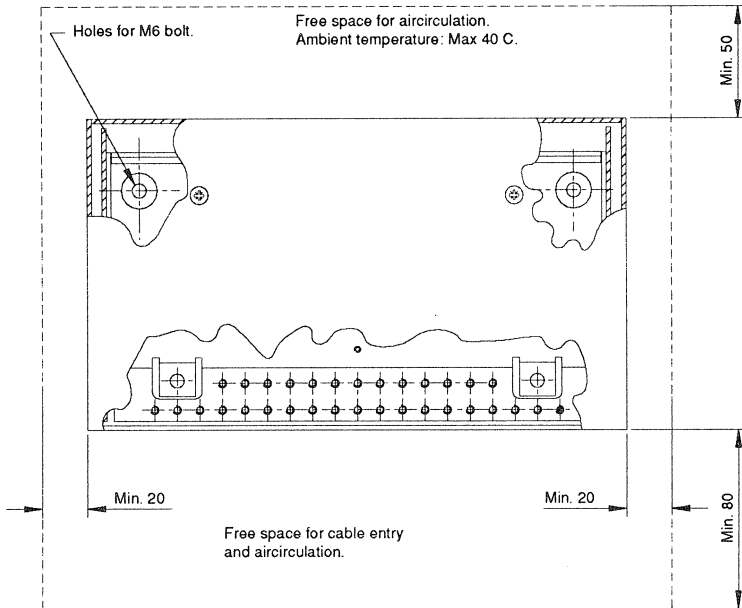

FRONT VIEW

2.2 DIMENSIONS AND DRILLING PLAN

N2165
4-0-27468 4-0-27464A

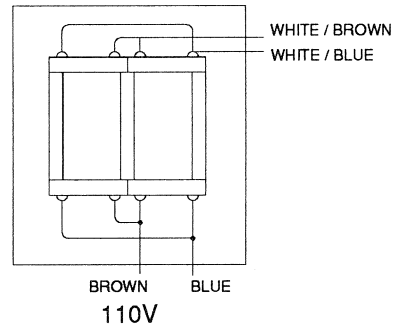
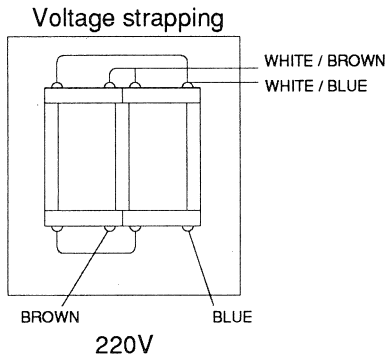
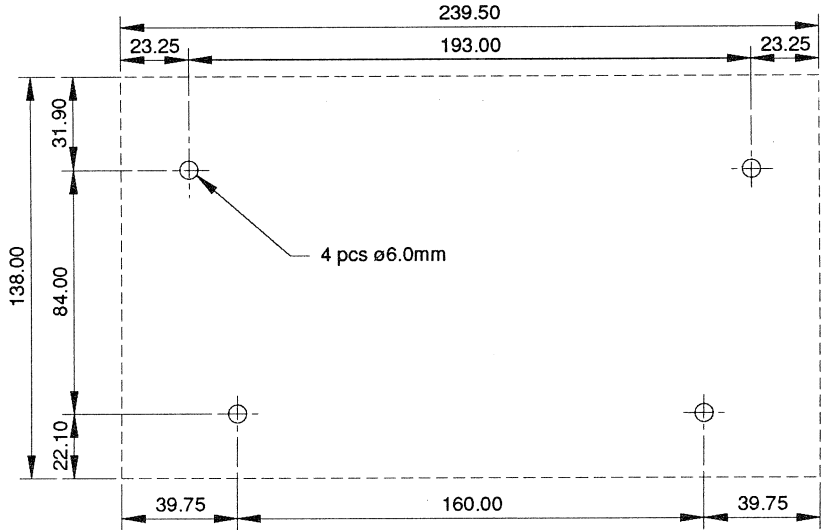

2.3. ELECTRICAL CONNECTION AND ASSEMBLING

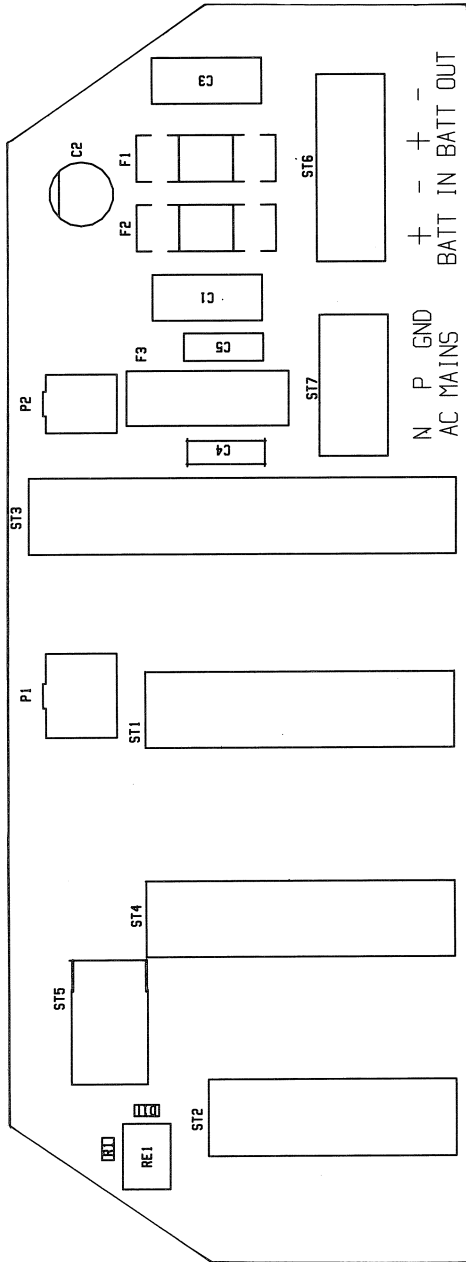

2.3. ELECTRICAL CONNECTION AND ASSEMBLING cont.:

N2165	RM2150 RM2151		
ST1	P2-5	COLOUR	SIGNAL
1	16	BROWN/GREY	HT-ON
2	6	YELLOW	SP-BUS INTERRUPT
3	15	BROWN/GREEN	TX-KEY
4	18	WHITE/YELLOW	AF TO TX
5	9	BLUE	AF TO TX COMMON
6	17	WHITE/PINK	DATA 1000B
7	21	WHITE/GREEN	CLOCK 1000B
8	24	GREY/PINK	EXT LOUDSP.
9	14	BROWN/YELLOW	RX-MUTE
10			SPARE

2.3. ELECTRICAL CONNECTION AND ASSEMBLING cont.:

N2165	RM2150 RM2151		
ST3	P2-5	COLOUR	SIGNAL
1	13	BROWN/PINK	SUPPLY ON/OFF
2	25	RED/BLUE	-BATT
3	12	WHITE	+18V
4	10	VIOLET	-18V
5	11	GREY	+9V
6	22	WHITE/BLUE	GROUND
7	4	PINK	EXT. ALARM
8	2	BROWN	ALARM IN
9	7	GREEN	ALARM OUT
10			SPARE
11			SPARE
12	1	BLACK	EXT. MUTE
13	3	RED	TX-READY
14	23	WHITE/GREY	COMMON

2.3. ELECTRICAL CONNECTION AND ASSEMBLING cont.:

Cable between N2165 and SAILOR HF SSB Transmitters
Cable specification:

T2130: 3 x 0.18 mm² max. 30 metres

T2131/35: 3 x 0.18 mm² max. 30 metres

T1130/H1233: 9 x 0.18 mm² max. 10 metres

T1135/H1275: 9 x 0.18 mm² max. 10 metres

N2165	T2130	T2131/ T2135	H1233/ H1275	SIGNAL
ST4	ST3 & ST2	ST7	ST102	
1			2	EXT. MUTE
2			5	TUNE READY
3			12	COMMON
4			3	HT ON
5	ST2-16	12		SP-BUS INTERRUPT
6	ST3-5	8	11	TX-KEY
7	ST3-7	10	13	AF TO TX
8	ST3-8	11	14	AF TO TX COMMON
9				
10				
	ST3-6 ST2-4	ST7-2 ST7-9		SEE NOTE 1 AND NOTE 2

N2165A

2.3. ELECTRICAL CONNECTION AND ASSEMBLING cont.:

NOTE 1

T2130 connection board

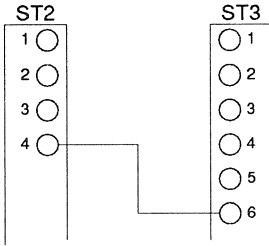

NOTE 2

T2131/T2135 connection board

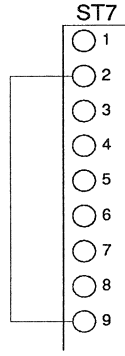

T1130/T1135 connection board

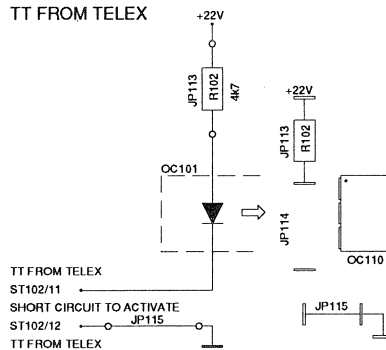
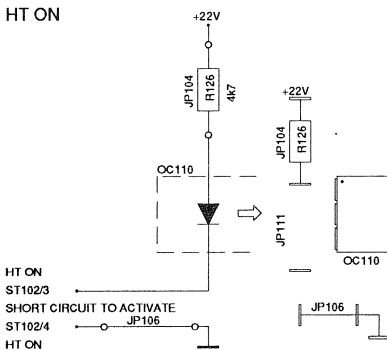
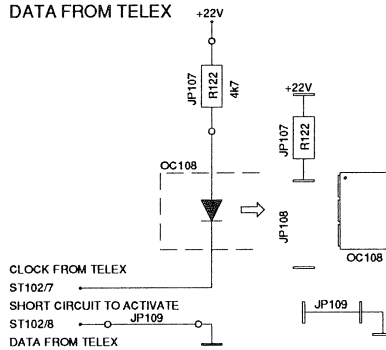
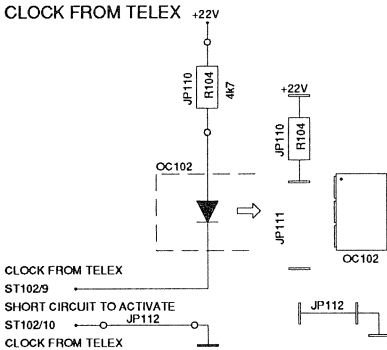

3. SERVICE

3.1. MAINTENANCE

PREVENTIVE MAINTENANCE

If SAILOR N2165 has been installed in a proper way the maintenance can be reduced to an overhaul at each visit of the service staff.

Then inspect the set, the antenna, cables, and plugs for mechanical damages, salt deposits, corrosion, and any foreign material.

Owing to its traditional structure, the SAILOR N2165 has a long lifetime, but it must always be carefully checked at intervals not exceeding 12 months - dependent on the conditions under which the set is working. The set must be brought to the service workshop to be tested.

Along with each set a TEST-SHEET is delivered in which all the measurements, made in the test department of the factory, are listed. If the control measurements made in the service workshop should not show the same values as those listed in the test-sheet, the set must be adjusted as specified in chapter 3.6.

ADJUSTMENT PROCEDURE.

3.2. ALIGNMENT INSTRUCTIONS

INTRODUCTION

The measuring values indicated in chapter 5. CIRCUIT DESCRIPTION AND SCHEMATIC DIAGRAMS are typical values and as indicated it will be necessary to use instruments in absolute conformity with the below list.

3.3. PROPOSAL FOR NECESSARY MEASURING INSTRUMENTS

Power Supply 20-50V, 10A

Oscilloscope type PM3216

Electronic Multimeter type PM2505:

Load +18V, 18 ohm/20W

PHILIPS

PHILIPS

-18V, 37 ohm/10W

+9V, 5.6 ohm/14W

3.4. TROUBLE SHOOTING

Trouble shooting should only be performed by persons with sufficient technical knowledge, who have carefully studied the operation principles and structure of the power supply N2165.

SAILOR N2165 has a trimmer, which must not be touched, unless adjusted as specified in chapter 3.6. ADJUSTMENT PROCEDURE.

When measuring the unit, shortcircuits must be avoided as the transistors would be spoiled.

3.5. PERFORMANCE CHECK

The performance check has to be carried out with the dummy load, specified in chapter 3.3., connected to the output.

1. Connect the power supply to 220V (be sure that the power supply is set to 220V).
2. Turn the power supply on by connecting ST3 pin 1 to ST3 pin 2.
3. Check the voltage from pin 3 to pin 4 at P1 on the power supply (module 9). It has to be $30V \pm 2V$ AC.
4. Check the voltage at the connection board ST3.
With pin 6 as ground, measure the voltage (DC) at:
pin 3 $+18.7V \pm 0.5$
pin 4 $-19.3V \pm 0.3$
pin 5 $+8.4V \pm 0.4$
5. Check with an oscilloscope the curve forms at the drains of Q3, Q4 on module 9 (see the diagram).
6. Connect a variable power supply to the battery input terminals on module 1. Connect a voltmeter from ST3 pin 6 to pin 3 (18V) on module 1.
7. Check the overvoltage shot-down circuit by increasing the voltage from the variable power supply until the +18V drops. The input voltage from the variable power supply should now be $45V \pm 5V$.

3.6. ADJUSTMENT PROCEDURE

There is only one adjustment in the power supply, that is adjustment of the overvoltage shot-down.

1. Connect a variable power supply to the battery input terminals on module 1. Connect a voltmeter from ST3 pin 6 to pin 3 (18V) on module 1.
2. Adjust the variable power supply to 45V. Then adjust R11 on module 9, so that the power supply just shots down. (+18V drops).

3.7. NECESSARY ADJUSTMENT AFTER REPAIR

Adjustments are only necessary after change of U1, when the overvoltage shot-down circuit needs adjustment as described in chapter 3.6.

4.1. MECHANICAL DISASSEMBLING AND
MODULE LOCATION

N2165

5. CIRCUIT DESCRIPTION AND SCHEMATIC DIAGRAMS

5.1. CONNECTION BOARD (MODULE 1)

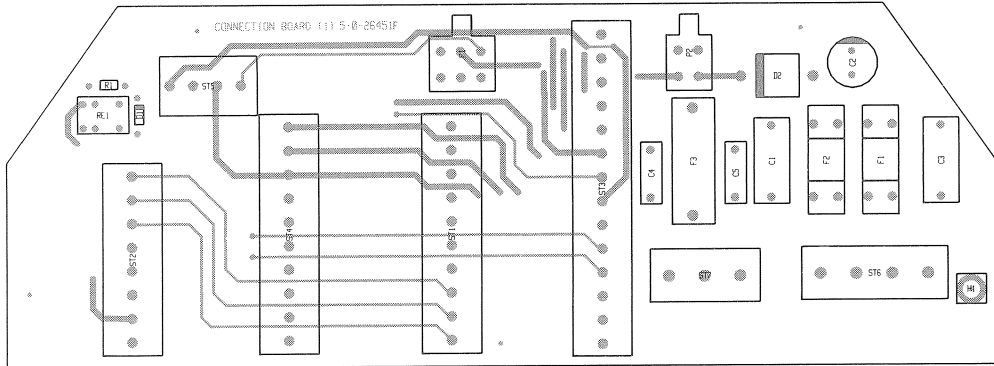

View from component side with upper side tracks.

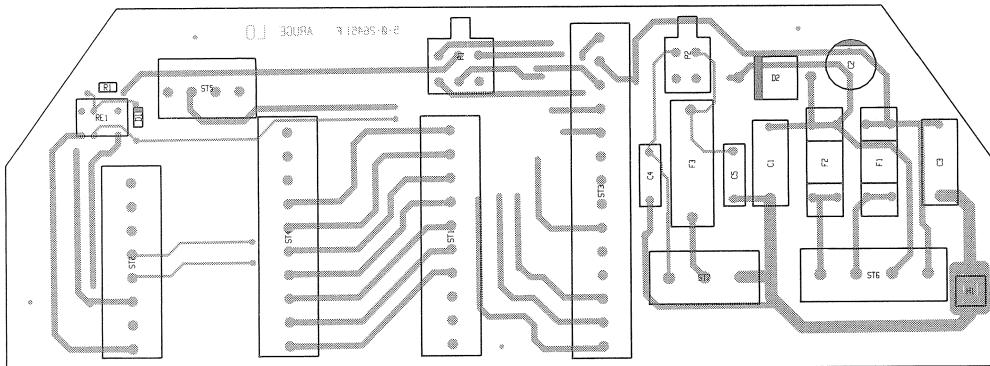

View from component side with lower side tracks.

N2165 4-0-26451D

Connection Board (1)

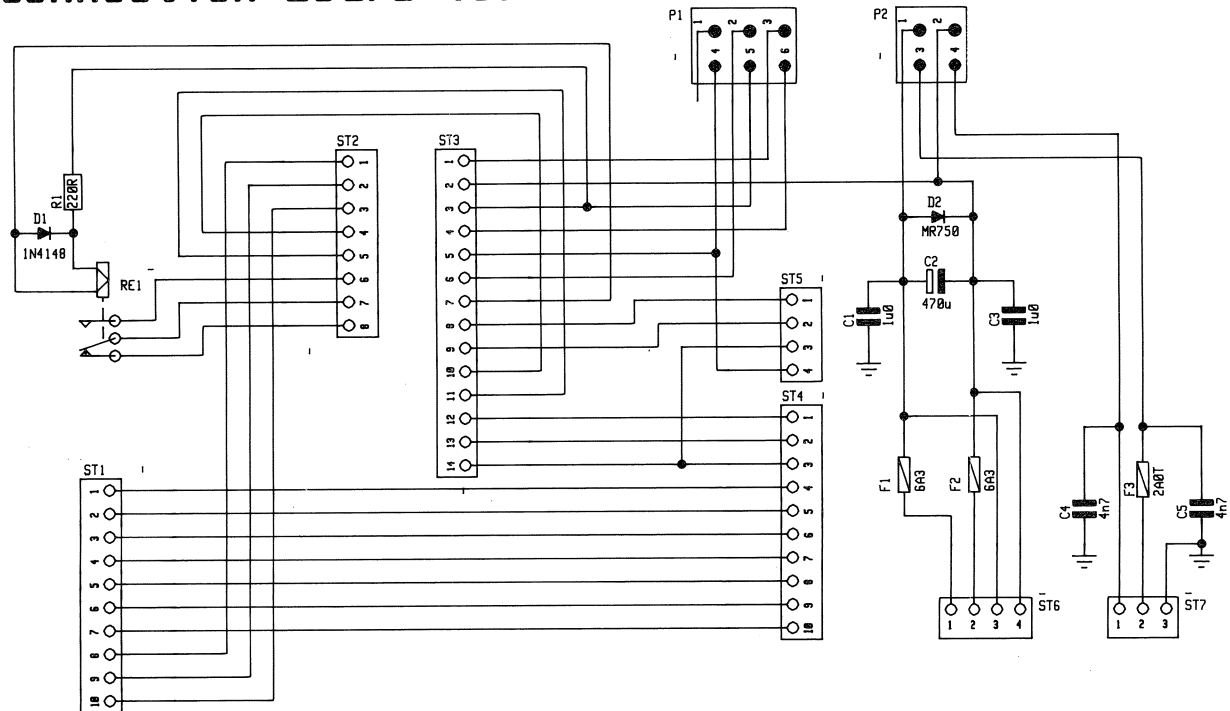

TO RM2150/51
ST1

- PIN 1 HT ON
- PIN 2 SP-BUS INTERRUPT
- PIN 3 TX KEY
- PIN 4 AF TO TX
- PIN 5 AF TO TX COMMEN
- PIN 6 DATA 1000B
- PIN 7 CLOCK 1000B
- PIN 8 SPARE
- PIN 9 SPARE
- PIN 10 SPARE

TO EXT. ALARM
ST2

- PIN 1 SPARE
- PIN 2 SPARE
- PIN 3 SPARE
- PIN 4 LINE IN
- PIN 5 LINE IN
- PIN 6 ETX.-ALARM NO
- PIN 7 ETX.-ALARM C
- PIN 8 ETX.-ALARM NC

TO RM2150/51
ST3

- PIN 1 SUPPLY ON/OFF
- PIN 2 -BATT
- PIN 3 +18V
- PIN 4 -18V
- PIN 5 +9V
- PIN 6 GROUND
- PIN 7 EXT.-ALARM
- PIN 8 ALARM IN
- PIN 9 ALARM OUT
- PIN 10 LINE IN
- PIN 11 LINE IN
- PIN 12 EXT MUTE
- PIN 13 TX-READY
- PIN 14 COMMEN

TO TRANSMITTER
ST4

- PIN 1 EXT MUTE
- PIN 2 TX-READY
- PIN 3 COMMEN
- PIN 4 HT ON
- PIN 5 SP-BUS INTERRUPT
- PIN 6 TX KEY
- PIN 7 AF TO TX
- PIN 8 AF TO TX COMMEN
- PIN 9 DATA 1000B
- PIN 10 CLOCK 1000B

TO C2149
ST5

- PIN 1 ALARM IN
 - PIN 2 ALARM OUT
 - PIN 3 COMMEN
 - PIN 4 9V
- ST6 TO BATTERY
- PIN 1 +BATT IN
 - PIN 2 -BATT IN
 - PIN 3 +BATT OUT
 - PIN 4 -BATT OUT

P1 TO POWER SUPPLY

- PIN 1 AC SENSE
- PIN 2 GND
- PIN 3 SUPPLY ON/OFF
- PIN 4 +9V
- PIN 5 +18V
- PIN 6 -18V

P2 TO POWER SUPPLY

- ST7 TO 110/220V AC
- PIN 1 N-AC
 - PIN 2 P-AC
 - PIN 3 GND

- PIN 1 +BATT
- PIN 2 -BATT
- PIN 3 P-220V AC
- PIN 4 N-220V AC

5.2. POWER SUPPLY (MODULE 9) No. 626409

The power supply is an isolated forward switch mode converter. It converts a 24V -19% +30% DCV voltage to $\pm 19V$ and 9V.

Most of the necessary amplifiers, flip-flops etc. are contained in the ICU1. The only exception from this, is the secondary voltage sense D18.

C2, C26, C27, L1, C3, C4 and C12, C13 are the input filter. The 12V DC supply voltage for U1 is supplied to R2, D7, C8, Q4 and C9 during starting-up. When the converter is in function it is supplied by L2 and D8, D9. This voltage is approx. 15 Volt and forces Q1 to turn off. This configuration reduces the power loss in Q1. R5 and C7 determine the oscillator frequency to approx. 50 kHz.

The +18V DC output voltage is sensed by D18 via the voltage divider R27 and R28. D18 is an integrated shunt regulator. If the voltage on the sense input (R27/R28 common point) is higher than 2.5V, then the D18 starts conducting. In this case, current starts running in the optocoupler diode OC2.

R26 is a DC feed-back and R25/C19 is an AC feed-back.

R24 limits the current in the optocoupler diode.

When current runs in the optocoupler diode, the optocoupler transistor (OC2) starts conducting nearly the same current. This current results in a voltage across R6. This voltage is connected to the non inverting input of the internal error amplifier of U1. The internal error amplifier is fixed to a gain of 2 by R7 and R8.

The output MOS transistor current is sensed by R17 and R18. The current signal is then led to the current sense amplifier input, pin 4. The R15 and C11 is a lowpass filter to remove noise. The emitter of Q2 follows the ramp voltage on the oscillator capacitor C7. R12 adds some of this ramp signal to the current signal. This is necessary to avoid sub-harmonic oscillations when the duty cycle is higher than 50%.

The voltage on pin 1 determines the clamp voltage for the error voltage and thus also the max. current in the output MOS transistors. This voltage is determined by R3 and R4. The capacitor C6 is the soft start capacitor, making the duty cycle and the output voltage rise slowly.

5.2 POWER SUPPLY (MODULE 9) No.626409 cont.:

The two pulse width modulated outputs are led to the two output MOS transistors by R13 and R14. These two resistors slow down the rising time of the MOS transistors to prevent spurious oscillations. R16 and R20 ensure that the transistors always stay off when the IC U1 is off.

R19, C15 and R21, C16 and R22, C17 and R23, C18 are snappers reducing oscillation due to stray capacitors and stray inductions in the transformer TR1.

D12 to D17 and L3 to L5 and C20 to C25 are the three output rectifiers and filters.

The input voltage is sensed by a 0.35 Volt shut down terminal pin 16 of U1 via R9, R10 and R11.

If the supply voltage is higher than approx. 45V DC, the converter stops.5.2.

5.2. POWER SUPPLY (MODULE 9) cont.:

COMPONENT LOCATION POWER SUPPLY MODULE 9

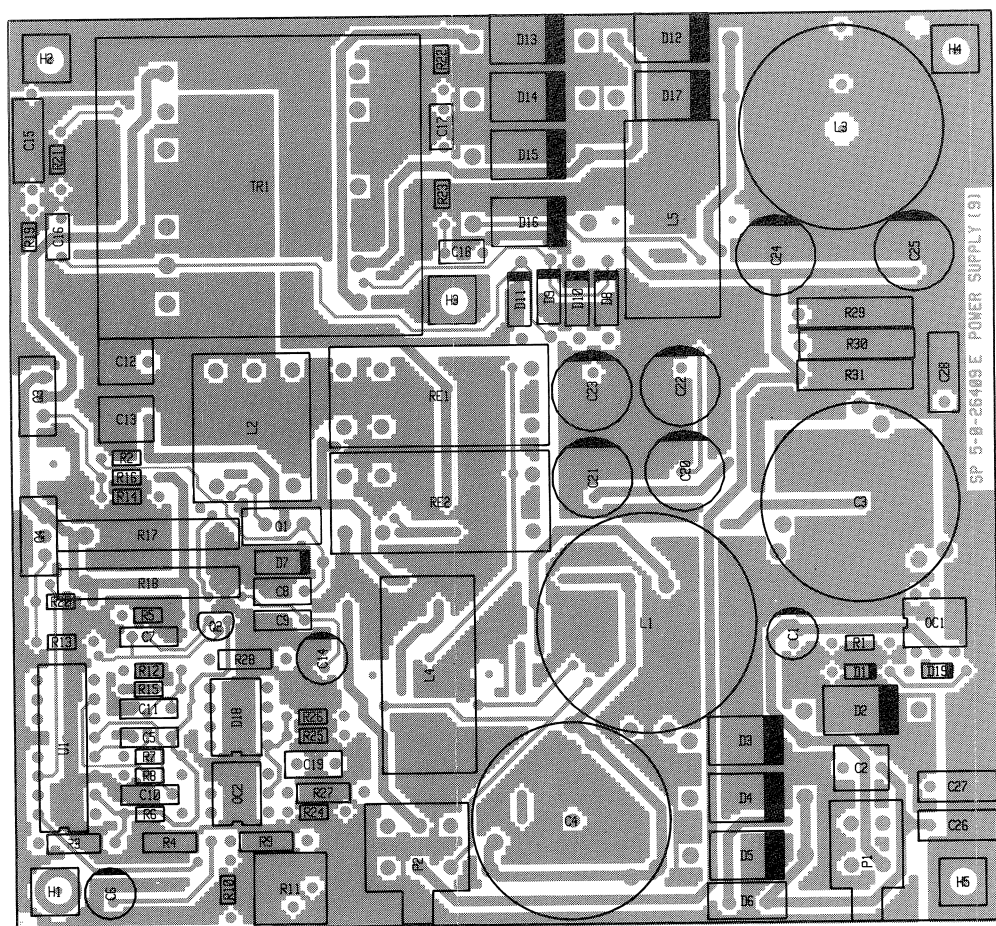

View from component side with upper side tracks.

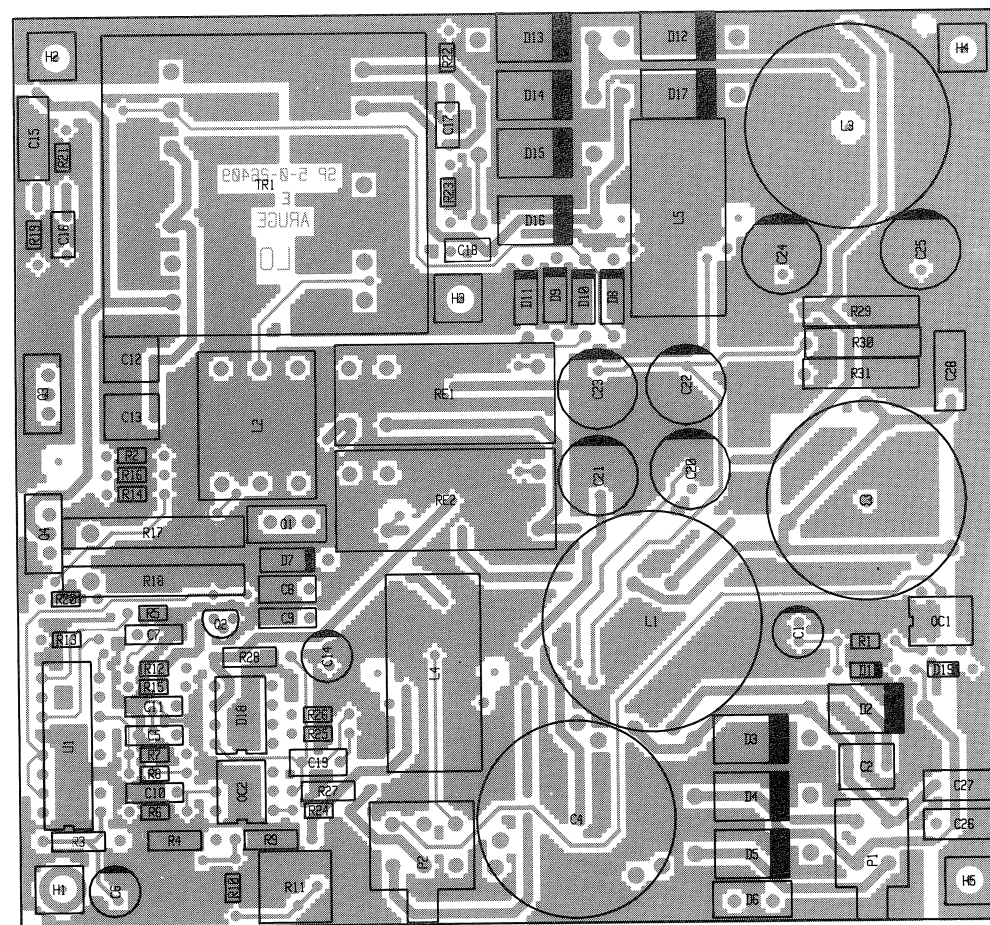

View from component side with lower side tracks.

5.2. POWER SUPPLY (MODULE 9) cont.:

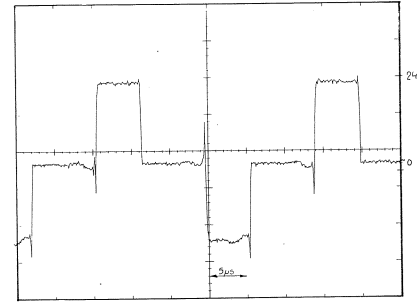

N2165
4-0-26409E 4-0-27470

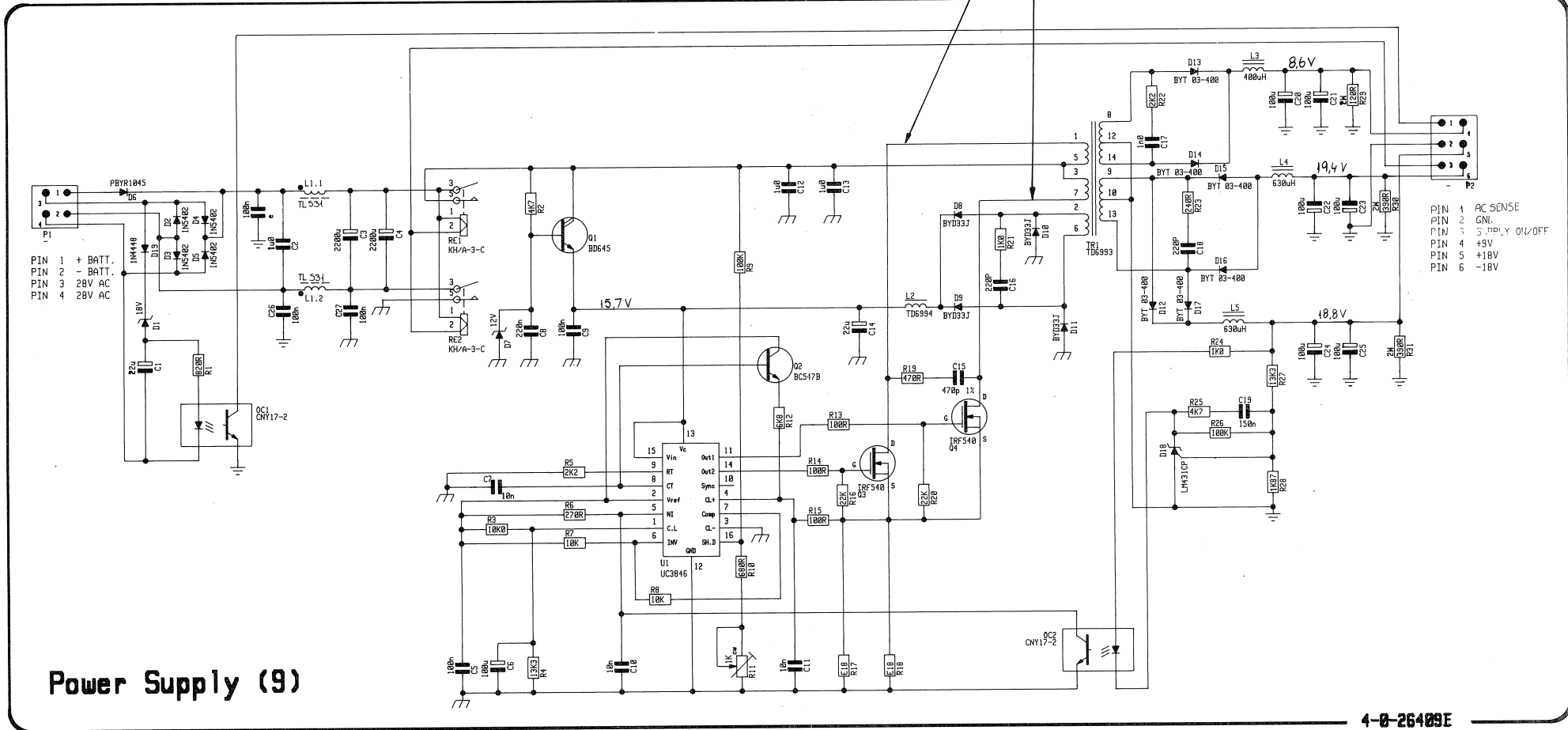

Power Supply (9)

5.3 INTERCONNECTION CABLE DIAGRAM

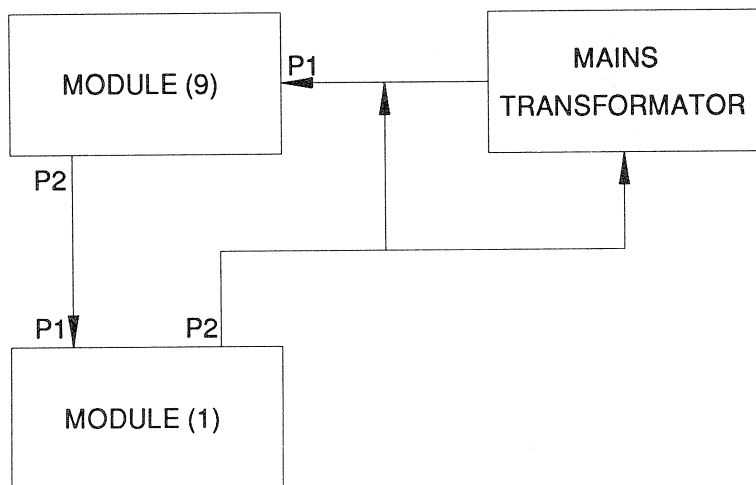

N2165
4-0-27469

CONNECTION BOARD (1)

POWER SUPPLY (9)

P1		P2
1	----- AC SENSE -----	1
2	----- GND -----	2
3	----- SUPPLY ON/OFF -----	3
4	----- +9V -----	4
5	----- +18V -----	5
6	----- -18V -----	6

P2		P1
1	----- +BATT -----	1
2	----- -BATT -----	2
3	- P-220V AC MAINS TRANSFORMATOR 28V AC	3
4	- N-220V AC MAINS TRANSFORMATOR 28V AC	4

6. PARTS LIST

POSITION	DESCRIPTION		MANUFACTURER	TYPE	S.P. NUMBER
	N2165		ESPERA	N2165	802165
VARIOUS	CAPACITOR MKT	100nF 10% 630V	ERO	MKT1822	11.163
VARIOUS	CABINET N2165	SAILOR GREEN		226454 GR0N RILSAN ALUMINIUM	141.328
VARIOUS	INSULATION WASCHER	SILICONE FOIL 18x12x0.18	* EFM	T0-220 18x12x0.18mm	30.541
VARIOUS	MOUNTING CLIP	T0-220 ENVELOPE	PHILIPS	56363	30.600
VARIOUS	CABLE 1 N2165	N2165	ESPERA	3-0-27065	527065
VARIOUS	LASHING KIT FOR T2130	AND N2160 / N2161	ESPERA	0-0-26141	726141
VARIOUS	SPARE FUSES F.N2165/HFSSB	N2165	S.P.RADIO	0-0-27245	727245
VARIOUS	MANUAL N2165 ENGLISH		S.P.RADIO A/S		M2165GB
-1	CONNECTION BOARD	MODULE 1 N2165	ESPERA	5-0-26451F	626451
-9	POWER SUPPLY MODULE 9	N2165	ESPERA	5-0-26409E	626409
TR1	TRANSFORMER MAINS	100VA N2165/T2131	TRADANIA A/S	6-0-26933	22.513
				Art.Nr. TD6977.1	

POSITION	DESCRIPTION		MANUFACTURER	TYPE	S.P. NUMBER
	SPARE FUSES F.N2165/HFSSB	N2165	S.P.RADIO	0-0-27245	727245
VARIOUS	FUSE	2AT 250V 5x20mm	ELU	179 120 2AT	45.508
VARIOUS	FUSE	5x20mm 6A3 T 250V	* ELU	17912006300	45.510

POSITION	DESCRIPTION		MANUFACTURER	TYPE	S.P. NUMBER
	CONNECTION BOARD	MODULE 1 N2165	ESPERA	5-0-26451F	626451
VARIOUS	FUSE HOLDER	1 POLE 5x20mm PCB VERSION	ELU	199015	78.398
VARIOUS	FUSE HOLDER	FOR PCB	SHURTER	06 751 0042	78.421
C1-1	CAPACITOR MKT	1u0F 10% 100VDC	PHILIPS	2222 373 21105	11.079
C2-1	CAPACITOR ELECTROLYTIC	470uF -20/+50% 40VDC	ERO	EKM 05 F6 347 G 05	14.650
C3-1	CAPACITOR MKT	1u0F 10% 100VDC	PHILIPS	2222 373 21105	11.079
C4-1	CAPACITOR CERAMIC	4.7N 5KV CL2	FERROPERM	9/0138,9 "D"	16.153
C5-1	CAPACITOR CERAMIC	4.7N 5KV CL2	FERROPERM	9/0138,9 "D"	16.153
D1-1	DIODE	1N4148 HIGH SPEED	PHILIPS	1N4148-143	25.131
D2-1	DIODE	MR750	MOTOROLA	MR750	25.219
F1-1	FUSE	5x20mm 6A3 T 250V	* ELU	17912006300	45.510
F2-1	FUSE	5x20mm 6A3 T 250V	* ELU	17912006300	45.510
F3-1	FUSE	2AT 250V 5x20mm	ELU	179 120 2AT	45.508
P1-1	MULTIPLUG	2x3 POLES PCB VERSION	MOLEX	39-28-1063	78.217
P2-1	PLUG 4 POLES		MOLEX	39-28-1043	78.216
R1-1	RESISTOR MF	220 OHM 5% 0.33W	PHILIPS	2322 160 73221	02.456
RE1-1	RELAY	12VDC 1SH. 2A.	MILTRONIC AB	0UC-S-1120	21.300
ST1-1	TERMINAL BLOCK	10 POLES 1.5mm2	PTR	AK300/10b m.MESS.SKRUER BLA	81.017
ST2-1	TERMINAL BLOCK	8 POLES 1.5mm2	PTR	AK300/8b m.MESS.SKRUER BLA	81.015
ST3-1	TERMINAL BLOCK	14 POLES 1.5mm2	PTR	AK300/14b m.MESS.SKRUER	81.029
ST4-1	TERMINAL BLOCK	10 POLES 1.5mm2	PTR	AK300/10b m.MESS.SKRUER BLA	81.017
ST5-1	TERMINAL BLOCK	4 POLES 1.5mm2	PTR	AK300/4b m.MESS.SKRUER BLA	81.025
ST6-1	TERMINAL BLOCK	4 POLES 2.5mm2	PTR	AK110/40S m.MESS.SKRUER	81.038
ST7-1	TERMINAL BLOCK	3 POLES 2.5mm2	PTR	AK110/30S m.MESS.SKRUER	81.037

POSITION	DESCRIPTION		MANUFACTURER	TYPE	S.P. NUMBER
	POWER SUPPLY MODULE 9	N2165	ESPERA	5-0-26409E	626409
C1-9	CAPACITOR ELECTROLYTIC	22uF 20% 35VDC	ERO	EKI 00 8B 222 F M9	14.516
C2-9	CAPACITOR MKT	1uF 10% 63VDC	PHILIPS	2222 370 78105	11.137
C3-9	CAPACITOR ELECTROLYTIC	2200uF -20/+50% 63VDC	PHILIPS	2222 021 48222	14.733
C4-9	CAPACITOR ELECTROLYTIC	2200uF -20/+50% 63VDC	PHILIPS	2222 021 48222	14.733
C5-9	CAPACITOR MKT	100nF 5% 63VDC	PHILIPS	2222 370 79104	11.135
C6-9	CAPACITOR ELECTROLYTIC	100uF 20% 10VDC	ERO	EKI 00 8B 310 C M9	14.607
C7-9	CAPACITOR MKT	10nF 20% 100VDC	PHILIPS	2222 370 38103	11.168
C8-9	CAPACITOR MKT	220nF 10% 63VDC	PHILIPS	2222 370 78224	11.095
C9-9	CAPACITOR MKT	100nF 5% 63VDC	PHILIPS	2222 370 79104	11.135
C10-9	CAPACITOR MKT	10nF 20% 100VDC	PHILIPS	2222 370 38103	11.168
C11-9	CAPACITOR MKT	10nF 20% 100VDC	PHILIPS	2222 370 38103	11.168
C12-9	CAPACITOR MKT	1uF 10% 63VDC	PHILIPS	2222 370 78105	11.137
C13-9	CAPACITOR MKT	1uF 10% 63VDC	PHILIPS	2222 370 78105	11.137
C14-9	CAPACITOR ELECTROLYTIC	22uF 20% 35VDC	ERO	EKI 00 8B 222 F M9	14.516
C15-9	CAPACITOR POLYSTYRENE	470pF 1% 630VDC	PHILIPS	2222 431 84701	10.425
C16-9	CAPACITOR CERAMIC	220pF 10% 500VDC CL2	NKE	DT35-0465 758S B 221K500V FLAT PACK	16.090
C17-9	CAPACITOR CERAMIC	1n0F 10% CL2 500VDC	NKE	DT 360 758L B 102 K 500V FLAT PACK	15.160
C18-9	CAPACITOR CERAMIC	220pF 10% 500VDC CL2	NKE	DT35-0465 758S B 221K500V FLAT PACK	16.090
C19-9	CAPACITOR MKT	150nF 5% 50VDC	ERO	MKT 1826-415/06 4-G	11.181
C20-9	CAPACITOR ELECTROLYTIC	100uF -10/+50% 25VDC	ERO	EKM 00 CC 310 E 65	14.610

N2165 92/15

C21-9	CAPACITOR ELECTROLYTIC	100uF -10/+50% 25VDC	ERO	EKM 00 CC 310 E G5	14.610
C22-9	CAPACITOR ELECTROLYTIC	100uF -10/+50% 25VDC	ERO	EKM 00 CC 310 E G5	14.610
C23-9	CAPACITOR ELECTROLYTIC	100uF -10/+50% 25VDC	ERO	EKM 00 CC 310 E G5	14.610
C24-9	CAPACITOR ELECTROLYTIC	100uF -10/+50% 25VDC	ERO	EKM 00 CC 310 E G5	14.610
C25-9	CAPACITOR ELECTROLYTIC	100uF -10/+50% 25VDC	ERO	EKM 00 CC 310 E G5	14.610
C26-9	CAPACITOR MKT	100nF 10% 100VDC	PHILIPS	2222 371 28104	11.180
C26-9	CAPACITOR MKT	100nF 10% 100VDC	PHILIPS	2222 371 28104	11.180
C28-9	CAPACITOR MKT	100nF 10% 100VDC	PHILIPS	2222 371 28104	11.180
D1-9	DIODE ZENER	18V 5% 0.4W BZX79C18	PHILIPS	BZX79C18	26.564
D2-9	DIODE RECTIFIER	1N5402 200V/3A	PROMAX	1N5402	25.116
D3-9	DIODE RECTIFIER	1N5402 200V/3A	PROMAX	1N5402	25.116
D4-9	DIODE RECTIFIER	1N5402 200V/3A	PROMAX	1N5402	25.116
D5-9	DIODE RECTIFIER	1N5402 200V/3A	PROMAX	1N5402	25.116
D6-9	DIODE POWER	SCHOTTKY 45VDC/10A	PHILIPS	PBYR 1045	27.617
D7-9	ZENER DIODE	12V 5% 1.3W	PHILIPS	BZV85C12	26.638
D8-9	DIODE FAST RECOVERY	600VDC/1A	PHILIPS	BYD 33 J	27.150
D9-9	DIODE FAST RECOVERY	600VDC/1A	PHILIPS	BYD 33 J	27.150
D10-9	DIODE FAST RECOVERY	600VDC/1A	PHILIPS	BYD 33 J	27.150

POSITION	DESCRIPTION		MANUFACTURER	TYPE	S.P.NUMBER
D11-9	DIODE FAST RECOVERY	600VDC/1A	PHILIPS	BYD 33 J	27.150
D12-9	DIODE FAST RECOVERY	400V/3A	THOMSON	BYT 03-400 TAPED	25.212
D13-9	DIODE FAST RECOVERY	400V/3A	THOMSON	BYT 03-400 TAPED	25.212
D14-9	DIODE FAST RECOVERY	400V/3A	THOMSON	BYT 03-400 TAPED	25.212
D15-9	DIODE FAST RECOVERY	400V/3A	THOMSON	BYT 03-400 TAPED	25.212
D16-9	DIODE FAST RECOVERY	400V/3A	THOMSON	BYT 03-400 TAPED	25.212
D17-9	DIODE FAST RECOVERY	400V/3A	THOMSON	BYT 03-400 TAPED	25.212
D18-9	DIODE SHUNT REGULATOR	PROGRAMMABLE	MOTOROLA	TL431CP	26.997
D19-9	DIODE HIGH SPEED	1N4448	PHILIPS	1N4448	25.147
L1-9	CHOKE	TL531	TRANS-ELECTRO	6-0-26309A	400531
L2-9	CHOKE FIXED	10mH/100mADC	TRADANIA	6-0-26623	20.254
L3-9	CHOKE FIXED TOROIDAL	400uH/2A +20/-12%	ULVECO	2-2.0-400-2-R (DK11752) UDT.IFLG.SP Tg:0-0-26192	20.245
L4-9	CHOKE FIXED TOROIDAL	630uH/1A6 +20/-12.5%	ULVECO	Art.Nr: DK11-542	20.244
L5-9	CHOKE FIXED TOROIDAL	630uH/1A6 +20/-12.5%	ULVECO	(2-1.6-630-1/SP Tg:26271) Art.Nr: DK11-542 (2-1.6-630-1/SP Tg:26271)	20.244
OC1-9	OPTO COUPLER	CNY17-2	TOSHIBA	CNY 17-2	32.530
OC2-9	OPTO COUPLER	CNY17-2	TOSHIBA	CNY 17-2	32.530
P1-9	PLUG 4 POLES		MOLEX	39-28-1043	78.216
P2-9	MULTIPLUG	2x3 POLES PCB VERSION	MOLEX	39-28-1063	78.217
Q1-9	TRANSISTOR AF POWER	NPN DARLINGTON T0220	PHILIPS	BD645	29.122
Q2-9	TRANSISTOR AF	BC547B NPN T0-92	PHILIPS	BC547B	28.067
Q3-9	TRANSISTOR POWER MOSFET	N-CHANNEL 100V/27A/85mOHM	MOTOROLA	IRF540	29.402
Q4-9	TRANSISTOR POWER MOSFET	N-CHANNEL 100V/27A/85mOHM	MOTOROLA	IRF540	29.402
R1-9	RESISTOR MF	820 OHM 5% 0.33W	PHILIPS	2322 180 73821	02.470
R2-9	RESISTOR MF	4k7 OHM 5% 0.33W	PHILIPS	2322 180 73472	02.488
R3-9	RESISTOR MF	10k0 OHM 1% 0.6W	* PHILIPS	2322 156 11003	03.427
R4-9	RESISTOR MF	13k3 OHM 1% 0.6W	PHILIPS	2322 156 11333	03.473
R5-9	RESISTOR MF	2k2 OHM 5% 0.33W	PHILIPS	2322 180 73222	02.480
R6-9	RESISTOR MF	270 OHM 5% 0.33W	PHILIPS	2322 180 73271	02.458
R7-9	RESISTOR MF	10k OHM 5% 0.33W	PHILIPS	2322 180 73103	02.496
R8-9	RESISTOR MF	10k OHM 5% 0.33W	PHILIPS	2322 180 73103	02.496
R9-9	RESISTOR MF	100k OHM 1% 0.6W	* PHILIPS	2322 156 11004	03.477
R10-9	RESISTOR MF	680 OHM 5% 0.33W	PHILIPS	2322 180 73681	02.468
R11-9	PRESET CERMET	1k0 OHM 10% 0.5W	BOURNS	3386P-1-102	07.886
R12-9	RESISTOR MF	6k8 OHM 5% 0.33W	PHILIPS	2322 180 73682	02.492
R13-9	RESISTOR MF	100 OHM 5% 0.33W	PHILIPS	2322 180 73101	02.448
R14-9	RESISTOR MF	100 OHM 5% 0.33W	PHILIPS	2322 180 73101	02.448
R15-9	RESISTOR MF	100 OHM 5% 0.33W	PHILIPS	2322 180 73101	02.448
R16-9	RESISTOR MF	22k OHM 5% 0.33W	PHILIPS	2322 180 73223	02.504
R17-9	RESISTOR WJW	R180 OHM 5% 2W	MODULOHM	R18-J-2W-E-1	06.220
R18-9	RESISTOR WJW	R180 OHM 5% 2W	MODULOHM	R18-J-2W-E-1	06.220

POSITION	DESCRIPTION		MANUFACTURER	TYPE	S.P.NUMBER
R19-9	RESISTOR MF	470 OHM 5% 0.33W	PHILIPS	2322 180 73471	02.464
R20-9	RESISTOR MF	22k OHM 5% 0.33W	PHILIPS	2322 180 73223	02.504
R21-9	RESISTOR MF	1k0 OHM 5% 0.33W	PHILIPS	2322 180 73102	02.472
R22-9	RESISTOR MF	2k2 OHM 5% 0.33W	PHILIPS	2322 180 73222	02.480
R23-9	RESISTOR MF	240 OHM 5% 0.33W	PHILIPS	2322 180 73241	02.457
R24-9	RESISTOR MF	1k0 OHM 5% 0.33W	PHILIPS	2322 180 73102	02.472
R25-9	RESISTOR MF	4k7 OHM 5% 0.33W	PHILIPS	2322 180 73472	02.488
R26-9	RESISTOR MF	100k OHM 5% 0.33W	PHILIPS	2322 180 73104	02.520
R27-9	RESISTOR MF	13k3 OHM 1% 0.6W	PHILIPS	2322 156 11333	03.473
R28-9	RESISTOR MF	1k87 OHM 1% 0.6W	PHILIPS	2322 156 11872	03.474
R29-9	RESISTOR PNF	120 OHM 5% 2W	PHILIPS	2322 191 31201	04.178
R30-9	RESISTOR PNF	390 OHM 5% 2W	PHILIPS	2322 194 13391	04.189
R31-9	RESISTOR PNF	390 OHM 5% 2W	PHILIPS	2322 194 13391	04.189
RE1-9	RELAY	24VDC 1NAKE 16A.	PASI	KH/A-3-C	21.027
RE2-9	RELAY	24VDC 1MAKE 16A.	PASI	KH/A-3-C	21.027
TR1-9	TRANSFORMER SMPS	35x40x43mm	TRADANIA	6-0-26620A	22.173
U1-9	CURRENT MODE PWM CONTROL.	UC3846	UNITRODE	Art.Nr: TD 6993.0 UC3846	31.486